

Version 1.0

UniSport Nationals 2023

Technical Guide

The competition is being run under the rules and regulations of AusCycling.

Commissaires Meeting 9.00am Wednesday 27th September at Luke Harrop Criterium Circuit

Riders will be briefed at the start of Road Races & Criterium 15 mins before start time

AusCycling Technical Officials

Competition Manager

- Charles Hall

Timing and Results Manager

- Neil Hamey

Technical Officials

- Michael Keetman (Chief)
- Peter Allonby
- Keith Ham
- Lise Benjamin
- Andre Bondeson
- Nanette Richert

VENUES AND FACILITY ADDRESSES

The following information provides the location and address for each sport competition venue.

Gold Coast Performance Centre (GCPC) Luke Harrop Criterium Circuit
1 Sports Drive, Runaway Bay QLD 4216

Gold Coast Cycle Centre
1 Hope Street, Nerang Qld 4211



ROAD CYCLING

Time Trial & Criterium Course Map – Luke Harrop Criterium Circuit

Individual Time Trial & Pairs Time Trial – Clockwise

Criterium – Anti Clockwise

Start & Finish



Park Here



COMPETITION DAY 1: Wednesday September 27TH

Time	Venue
10.00am – 1.00pm	Luke Harrop Criterium Circuit

Men	10.00am	Individual Time Trial	20km
Women	11.00am	Individual Time Trial	20km
Mixed	2.00pm	Pairs Time Trial	20km

COMPETITION DAY 2: Thursday September 28TH

Time	Venue
10.00am – 1.00pm	Luke Harrop Criterium Circuit

Men	10.00am	Criterium	50 mins + 3 laps
Women	11.00am	Criterium	40 mins + 3 laps

Sign on is required for the Criterium



COMPETITION DAY 3:

Friday September 29TH

Road Race - clockwise

Riders Marshalling and Start

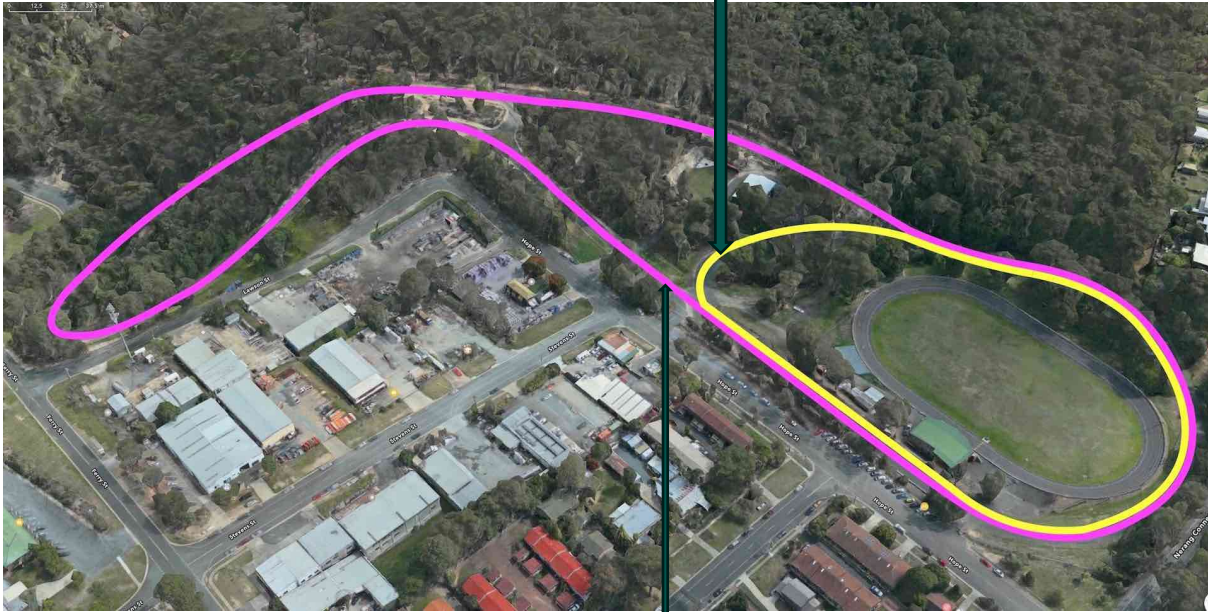

Finish

Time	Venue
10.00am – 2.00pm	Gold Coast Cycle Centre

Men 10.00am 60km

Women 12.00pm 40km

Sign on is required for the Road Race



GENERAL

Race Numbers for Criterium & RR

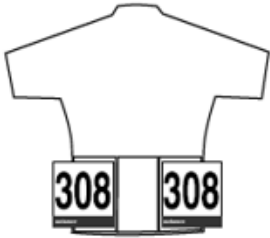

Time Trial – 1 number low centre of back

Electronic Timing



Electronic Timing will be used for all events at these championships. Therefore, riders are required to fit a small transponder to the front fork of your bicycle. The transponders will be issued with your race number at registration. DO NOT exchange your transponder with any other competitor as the transponder is coded to your race number. (Time Trials, Criterium and Road Race)

Transponders must be attached to bikes for all events

Additional zip ties will be available at registration.

Transponders must be returned after your last race at the start/finish line of the event.

Any rider failing to return their transponder at the event will incur a \$30 administration fee. Lost or damaged transponders will result in a replacement penalty of \$150



RESULTS

Results will also be available on the AusCycling Results Website: [AusCycling Event Results](#)

RADIO COMMUNICATIONS

During races in these Championships, the use of radio links or any other means of communication with the riders is not permitted.

NEUTRALISATION

If for any reason conditions warrant the race will be neutralised. In such circumstances a red flag will be displayed.

LITTERING

Riders must not discard bidons or rubbish of any kinds on the roadside. Riders found to be littering will be fined in accordance with local laws and technical regulations.

PUBLIC URINATION

Riders are advised that it is an offence to urinate in public. Penalties will be imposed on those who choose to ignore this law.

Riders are advised that it is an offence to urinate in public. Penalties will be imposed on those who choose to ignore this law.

MEDICAL EMERGENCY

For a medical emergency dial "000" for assistance



ANTI-DOPING REGULATIONS

Competitors, Coaches, Member Organisations, Event Organisers and Sport Technical Officers should read and understand the Sports Integrity procedures carefully and ensure they are upheld at every opportunity.

ADDITIONAL DO'S AND DON'TS

- Be responsible for your own safety, the safety of your own equipment and be considerate of the safety of others.
- No use of abusive language towards anyone.
- The use of mobile phones, MP3 players (iPods) or any electronic device is strictly prohibited during the event.
- Under no circumstances are you to interfere with any other competitors' property.
- Competitors may not accept assistance from anyone other than an authorised race official.
- No littering. No empty goo/gel packets on course!
- Your helmet must be fastened before the start of the race. In the event of a breakdown (mechanical) on the cycle course, your helmet must remain on and securely fastened.

BICYCLE REGULATIONS

Structure

4. Handlebars/Basebars

- A maximum width of 500 mm is allowed for the overall width (outside – outside) of handlebars. The minimum overall width (outside – outside) of traditional handlebars (road events) and base bars (road and track events) is limited to 350 mm.





5. Handlebar to front axle

- Handlebars are now permitted to be up to 100mm in front of the axle. The lowest point they can be is 100mm below the top of the tyre

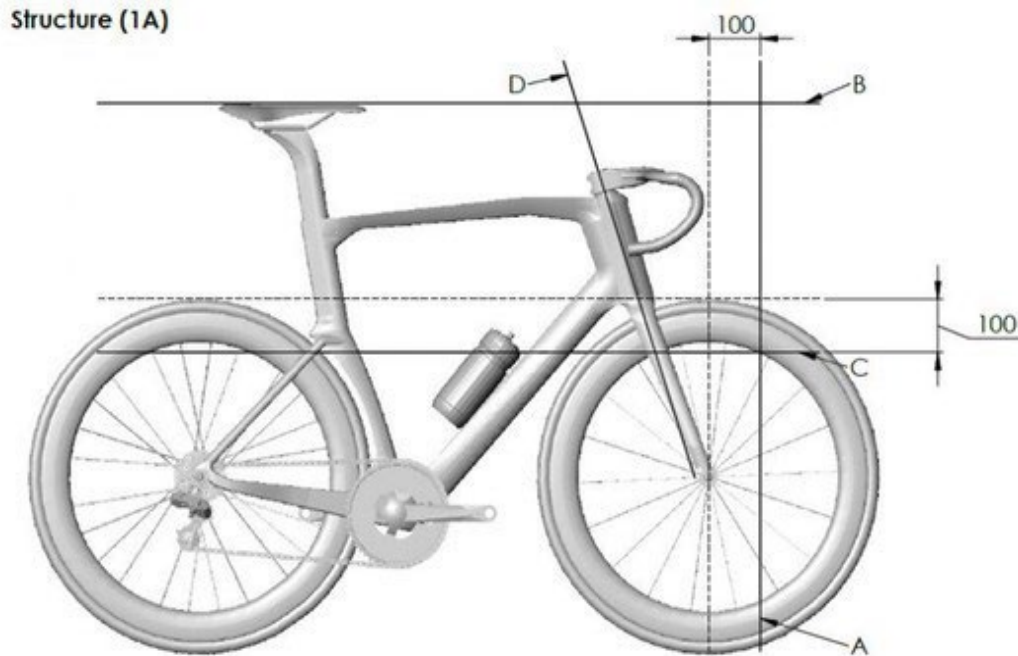

Figure 32: Illustration of the box, marked out by lines A, B, C and D, within which the handlebars must be fully contained.

Riders Height – Individual Pursuit, Team Pursuit & Time Trial

Riders less than 180cm tall (Category 1)

- For riders less than 180.0 cm tall, the horizontal distance between the vertical planes passing through the bottom bracket axle and the extremity of the fixed time trial extension handlebar, including all accessories, may be a maximum of 800 mm when the saddle is 50mm or more behind the bottom bracket. The height difference between the midpoint of the forearm support and the highest or lowest point of the extension (including accessory) must be less than 100 mm. When the saddle is less than 50mm behind the bottom bracket the maximum is 750mm

Riders between 180cm and 189.9cm tall (Category 2)

- For riders between 180.0 cm and 189.9 cm tall, the horizontal distance between the vertical planes passing through the bottom bracket axle and the extremity of the fixed time trial extension handlebar, including all accessories, may be a maximum of 830 mm. The height difference between the midpoint of the forearm support and the highest or lowest point of the extension (including accessory) must be less than 120 mm.

Riders 190cm + tall (Category 3)

- For riders 190.0 cm and taller, the horizontal distance between the vertical lines planes passing through the bottom bracket axle and the extremity of the fixed time trial extension



handlebar, including all accessories, may be extended to a maximum of 850 mm. The height difference between the midpoint of the forearm support and the highest or lowest point of the extension (including accessory) must be less than 140 mm.

- Junior 19 and Elite Riders in Category 3 must submit a rider height attestation application form, signed by a Doctor through the UCI portal
- Junior Under 17 and Masters riders email track@auscycling.org.au
- Once the form has been submitted you will be added to the list issued on UCI (Elite & Junior 19 only) and AusCycling Websites.
- Without the submission of the Height attestation form, no exemption will be issued and the standard regulations will apply

The base regulation has not changed:

- a. The tip of the saddle should be at least 50mm behind the centre of the Bottom Bracket.
- b. The tip of the extension should be no more than 750mm forward of the centre of the Bottom Bracket.
- c. The height difference from the centre of the forearm support and the tip of the extension should be no more than 100mm.
 - Riders wishing to use a position outside of the dimensions of points a or b are permitted one exemption.

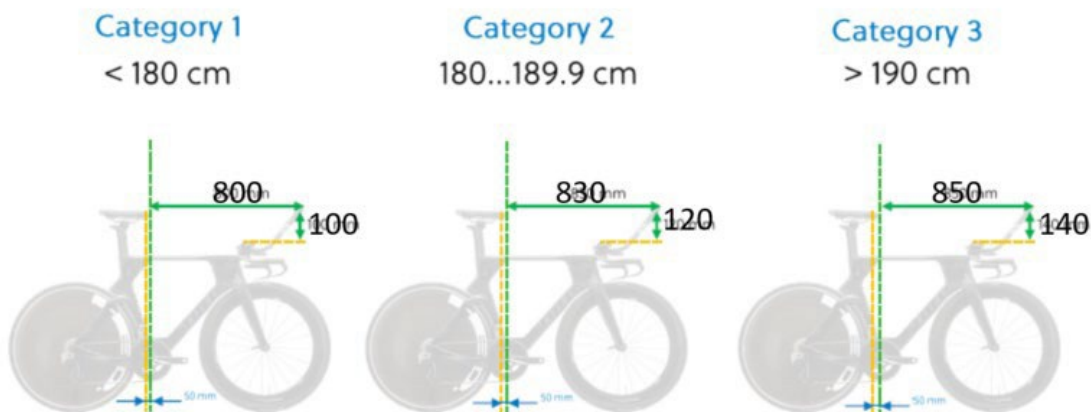

Forearm supports must be made up of two parts (one part for each forearm) and are only allowed when extensions are added.

- The maximum width and length of each forearm support is 125mm
- The minimum length of each forearm support is 60mm



- The maximum height of each forearm support is 85mm
- The maximum inclination of each forearm support is 30 degrees (measured on support surface)
- The minimum distance from the leading end of the forearm support to the tip of extensions is 180mm

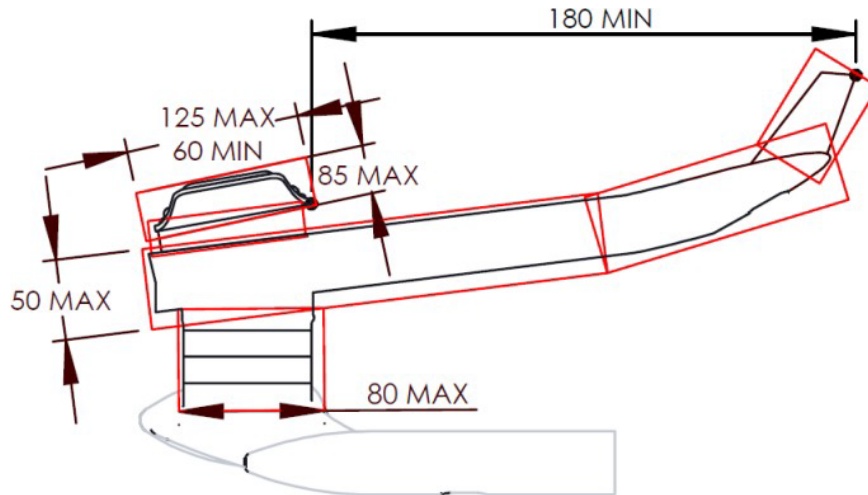

- Any binding element (bridge) between the fixed additional time trial extension handlebar, forearm supports is considered as the continuation of the fixed additional time trial extension handlebar. Therefore, the maximum dimension of the cross section of the binding element must be 50 mm.

Any binding element between stack/raisers spacers must follow the identical restrictions. The binding element must be positioned at the horizontal distance equal to 80 mm or greater, from the vertical plane passing through the extremity of the handlebars extensions

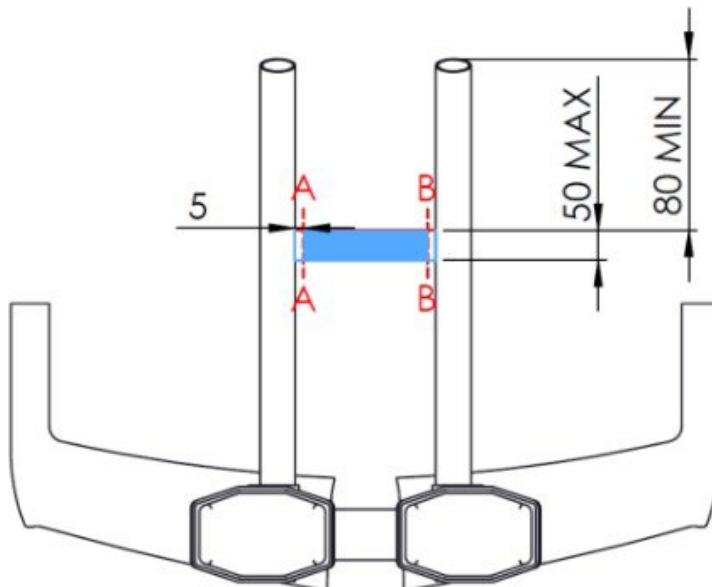



Helmets

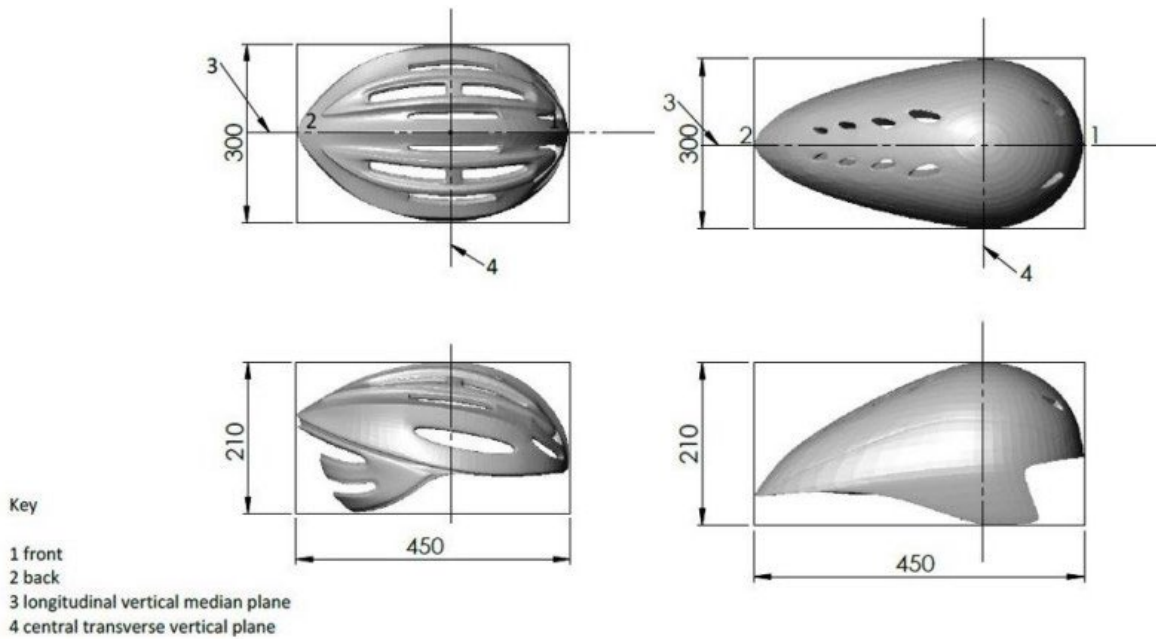

For road and track disciplines, the dimensions of the helmet (including accessories) must not exceed the above dimensions:

- a. Length (L) can be less or equal to 450 mm ;
- b. Width (W) can be less or equal to 300 mm ;
- c. Height (H) can be less or equal to 210 mm ;

VICTORY CEREMONIES

Organised by UniSport

In compliance with AusCycling Regulations

- no helmets or glasses to be worn on the podium
- Covered shoes to be worn
- Race Kit to be worn